

# T4



# Heating with wood chips and pellets

For more than 50 years, Froling has specialised in efficiently using wood as a source of energy. Today the name Froling represents modern biomass heating technology. Froling firewood, wood chip and pellet boilers are successfully in operation all over Europe. All of our products are manufactured in our factories in Austria and Germany, and our extensive service network ensures that we can handle all inquires quickly.



## The fuels: wood chips and pellets

**Wood chips** are an environmentally friendly fuel, unaffected by crises and fluctuations. Scrap wood from local forests is shredded into wood chips in a fully automatic process and transported to the fuel store. The added value stays in the region, thus securing jobs. That is why wood chip is the perfect fuel, not just from an economic perspective, but also from an environmental point of view.



**Wood pellets** are made of natural wood. The large volumes of wood shavings and sawdust generated by the wood-processing industry are compacted and pelleted without being treated beforehand. Pellets have a high energy output and are easy to deliver and store. These are just some of the advantages that make pellets the perfect fuel for fully automatic heating systems. Pellets are delivered by tanker and unloaded directly into your store.



**Switchgrass** or elephant grass (Latin name: miscanthus) is a plant from the Poaceae family native to south-east Asia. This fast-growing plant grows up to three metres high and is increasingly being used as a fuel because of its high calorific value and small carbon footprint.



## Multiple award-winning

Particular attention was paid to energy efficiency, durability and stability during the development of the T4. This priority was clearly confirmed when the boiler was awarded with the Austrian Ecolabel (for the wood chips and pellets) . The T4 consumes little electricity during operation, keeping the operating costs down.

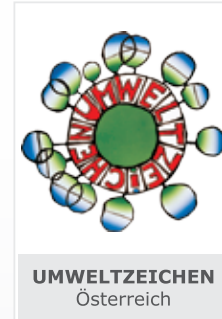

## The new Froling T4

User-friendly, compact, economical and safe: the new T4 from Froling meets all your needs. This boiler can efficiently burn both wood chips and pellets due to its intelligent fully-automatic system.

With the silicon carbide combustion chamber, the T4 ensures a high level of efficiency (up to 94.2%) with very low emissions. Well-planned use of energy-saving drives ensures extremely low energy consumption.

Thanks to its modular construction and compact dimensions, the Froling T4 is particularly easy to position and install.

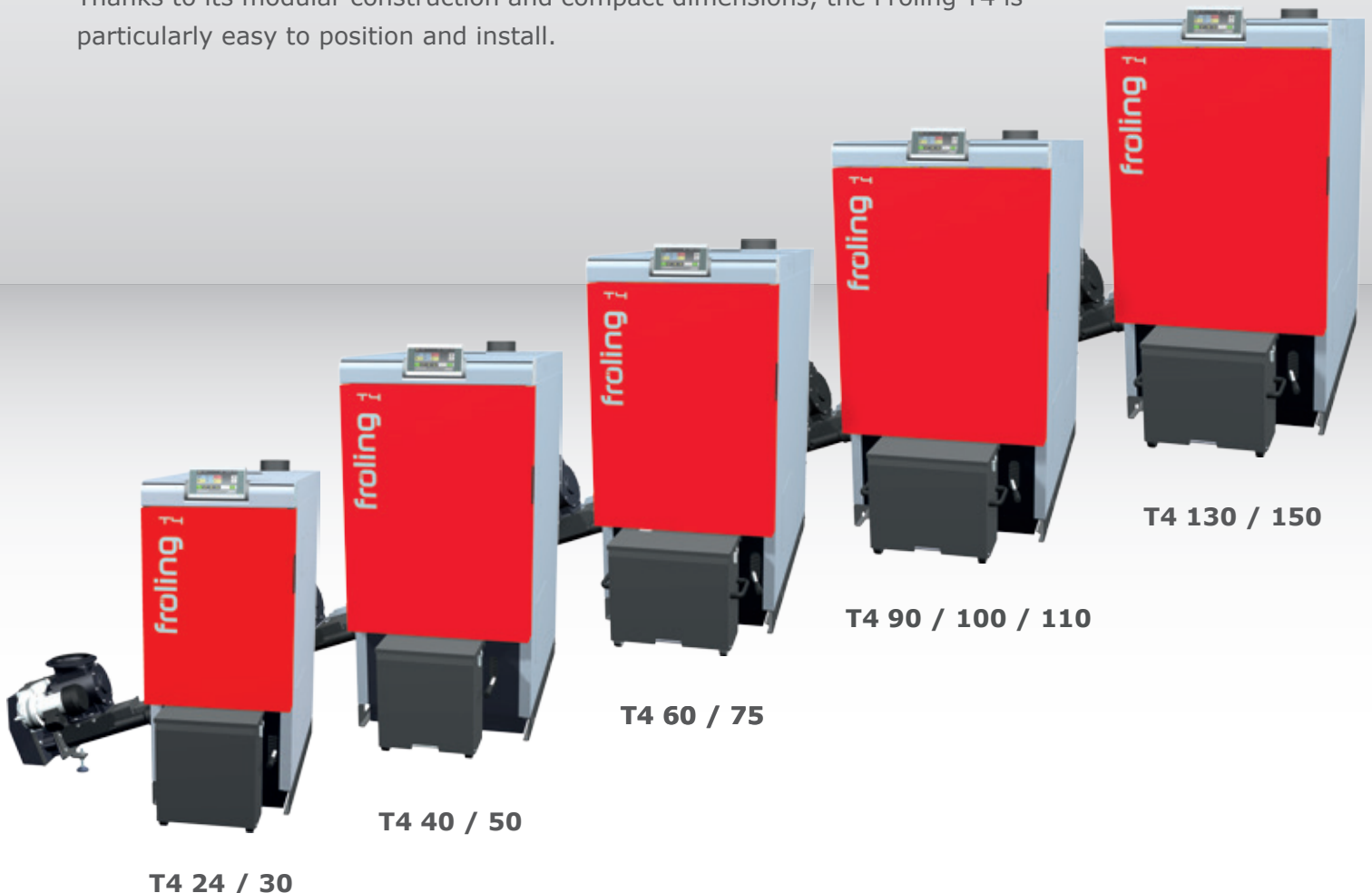



# Robust technology with intelligent features



## The new Froling T4 with special benefits:

- 1 Durable high-temperature silicon carbide combustion chamber for maximum shelf life and effective combustion with a high level of efficiency and very low emissions.
- 2 Multi-part combustion grate consisting of a fixed insertion zone and the automatic tipping grate for cleaning away ash and foreign bodies.
- 3 Automatic ash removal from the combustion chamber and the heat exchanger to the large mobile ash container using two separate ash screws (and a communal drive).
- 4 Precise primary and secondary air control for optimal adjustment to all load conditions.
- 5 Underpressure controller for optimal fuel adjustment.
- 6 3-pass heat exchanger with Efficiency Optimisation System - WOS (turbulators for automatic cleaning of the heat exchanger pipes). The second heat exchanger pass virtually cleans itself and only requires maintenance once or twice a year. Because there are no mechanical components in this extremely hot area, there is no need for the usual regular replacement of the turbulators.
- 7 Speed-controlled induced-draught fan with function monitor for maximum operational reliability.
- 8 Lambdatronic H 3200 control with 7" touch display and innovative bus technology  
Fully insulated to minimize radiant heat loss.
- 9 Broadband Lambda probe for automatic adjustment to different fuel qualities.
- 10 Large ash container for long emptying intervals.
- 11 Optional flue gas recirculation FGR.
- 12

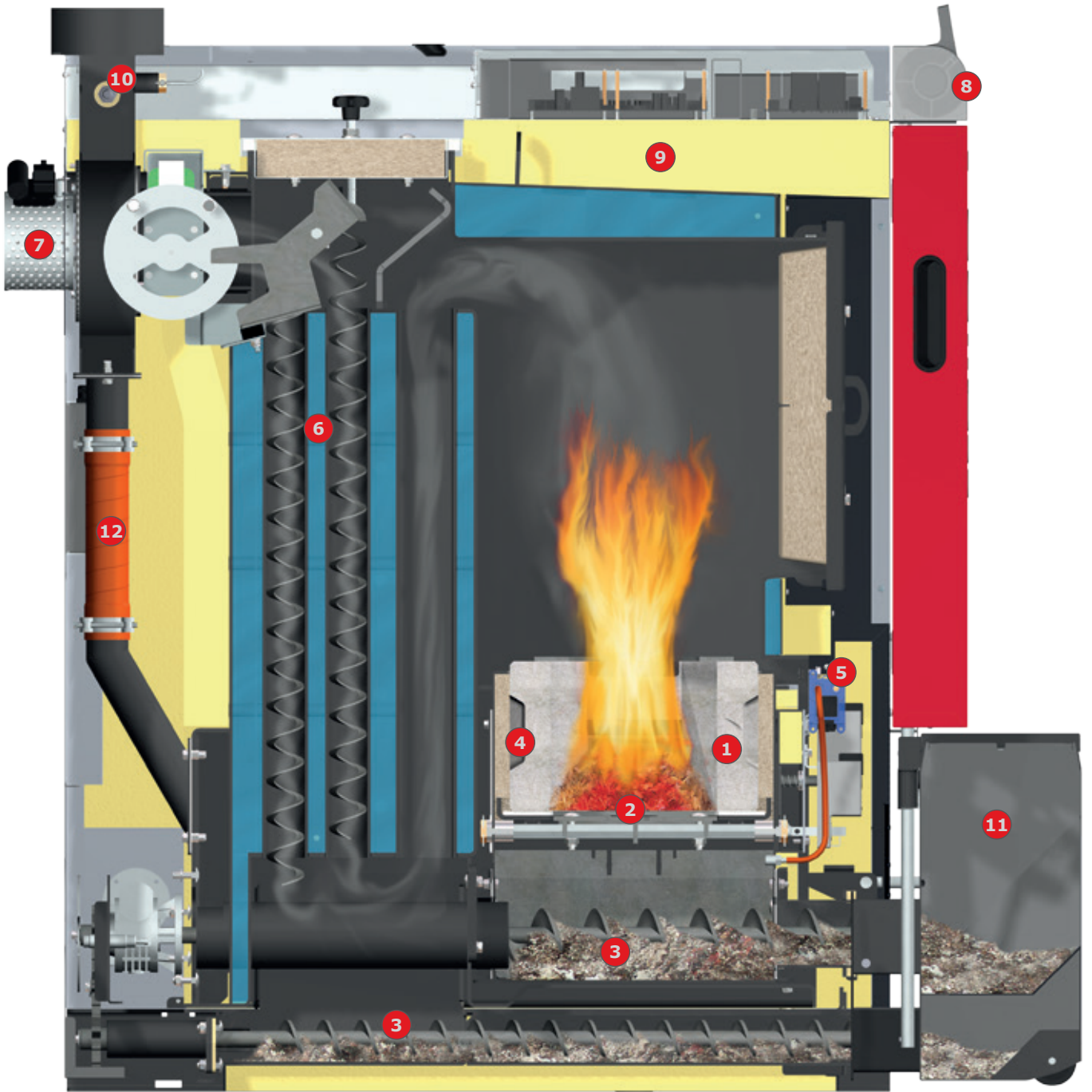



# A well-designed inside

## Feature: easy to assemble on site

- Advantages:
- quick assembly
  - pre-wired
  - stoker unit on the left or right as desired.

The T4 is supplied assembled and wired, you just need to fit the stoker unit and connect the chosen discharge system to the rotary valve. This saves time and money. Thanks to the well-planned layout of the units and its compact design, the T4 can also be used in very confined spaces.

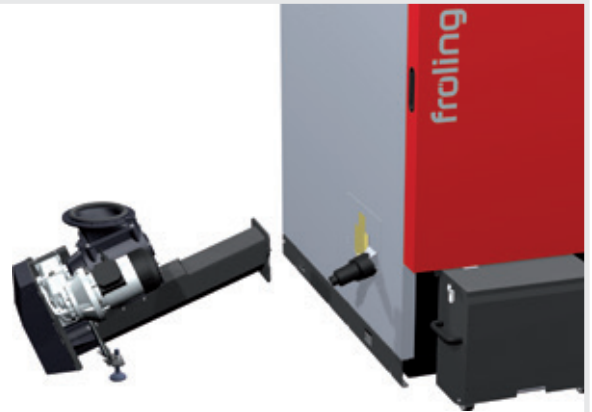

You can select a right or left-hand stoker unit.

## Feature: easy to maintain combustion chamber

- Advantages:
- pre-assembled unit
  - easy to service and maintain

The firebricks are made of high-quality silicon carbide and are extremely durable. Because it is designed as a single component, the entire unit can be easily removed for servicing and maintenance if necessary.

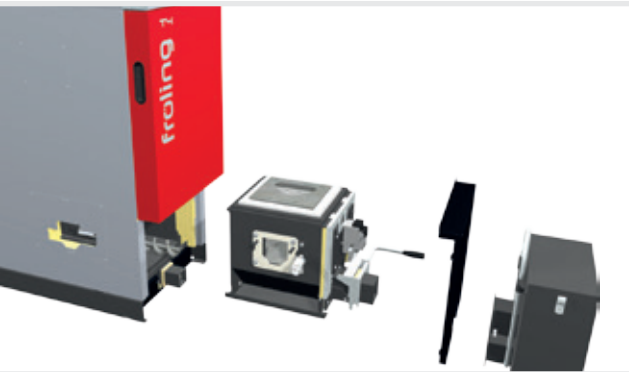

## Feature: quick ignition

- Advantages:
- automatic ignition using residual embers
  - powerful hot air blower for reliable ignition

Thanks to the hot combustion zone, after short periods in idle mode the fuel is automatically reignited by the residual embers. It is only necessary to start the ignition fan after longer combustion pauses. The 1.1 kW hot air blower can ignite any material within a few seconds if necessary.



## Feature: 3-pass heat exchanger with automatic cleaning (WOS)

- Advantages:
- more efficient
  - fuel savings

The WOS (Efficiency Optimisation System) consists of special turbulators, which are placed in the heat exchanger pipes and allow automatic cleaning of the heating surfaces. Clean heating surfaces ensure greater efficiency and thus fuel savings.

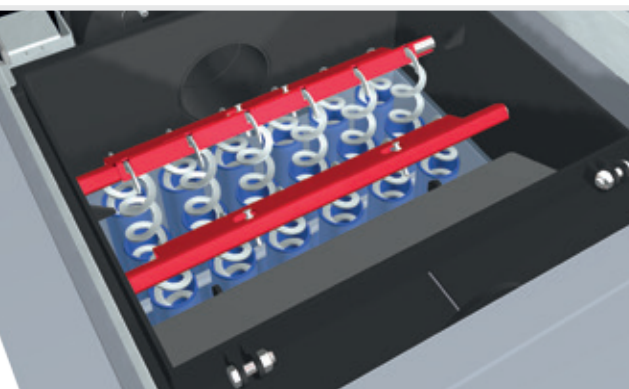

## High-temperature silicon carbide combustion chamber and perfect combustion control

- Advantages:
- optimal emission values
  - economical fuel consumption
  - adapts automatically to varying fuel qualities

The firebricks are made entirely of high-quality fireproof material (silicon carbide). The hot combustion zone ensures optimal combustion and very low emissions.

### Patented firebrick!

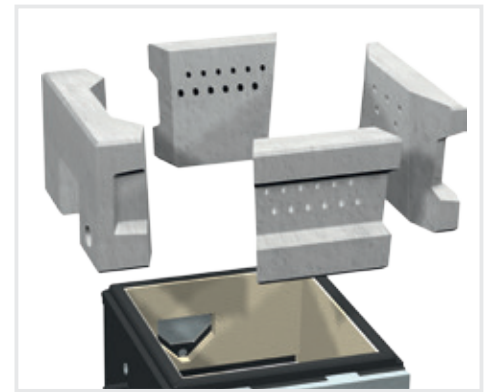

The patented shaping of the firebrick stones gives the air supply in the combustion chamber particularly good airtightness without the need to use expensive wearing seals. The new shape of the stones also considerably simplifies the maintenance of the combustion chamber as they can be removed easily.

### Precise primary and secondary air control

Combustion in the T4 is controlled by underpressure. Combined with the induced draught fan, this guarantees extremely high operating safety. The innovative control of air distribution in the combustion zone is a new feature - primary and secondary air are optimally adjusted to the conditions in the combustion chamber with a joint actuator. This, combined with the lambda controller which comes as standard, ensures that harmful emissions are kept to a minimum.

# A well-designed inside

## **Feature:** speed-regulated induced draught fan

- Advantages:
- maximum ease of use
  - constant stabilisation of combustion
  - quiet and energy-saving operation

The speed-regulated induced draught fan, which comes as standard, ensures the exact air quantity and constant underpressure throughout combustion. As the induced draught fan is speed-regulated, it stabilises combustion throughout and adjusts the output to requirements. The induced draught fan is also very quiet and energy-saving.

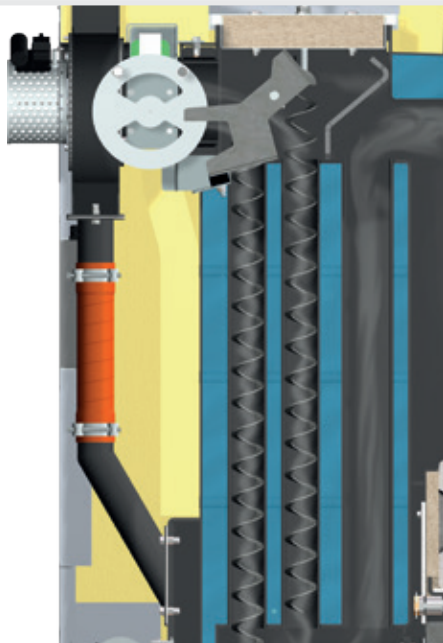
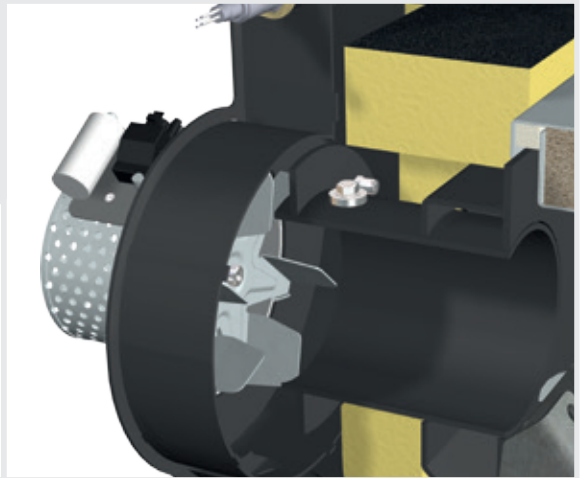

## **Feature:** flue gas recirculation (FGR) (optional)

- Advantages:
- ideal combustion conditions
  - intelligent regulation of the air quantity

The optional flue gas recirculation system (FGR) mixes part of the flue gas with the combustion air and returns it to the combustion zone. This regulates the air quantity using the position of the ash screw.

The FGR optimises combustion and performance, and also reduces NOx emissions. The lower combustion temperatures offer added protection for flame-swept parts.

## **Feature:** smart grate technology

- Advantages:
- ideal combustion conditions
  - automatic self-cleaning
  - Optimal glow retention

The combustion grate is divided in several sections to ensure optimal combustion of wood chips or pellets. The stationary lifting grate ensures even distribution of the fuel in the combustion zone. The centrally-supported tipping grate can pivot through 90°, and reliably cleans ash and residue from the combustion chamber. This grate is made of a special fire-proof alloy to guarantee an exceptionally long service life.

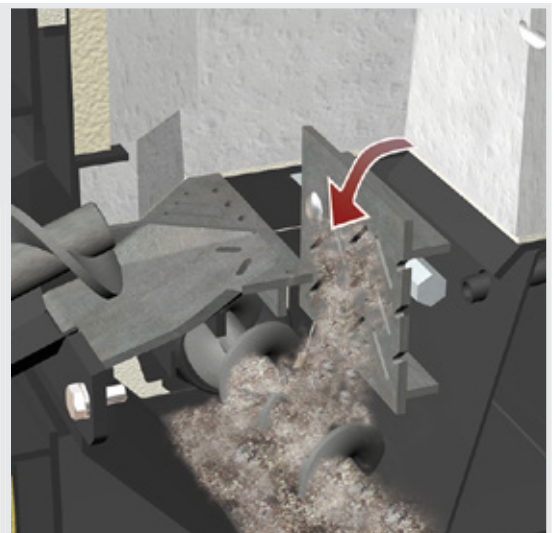



**Feature: ash discharge system with separate ash screws**

- Advantages:
- optimal emptying
  - no risk of air leakage thanks to two-chamber ash container

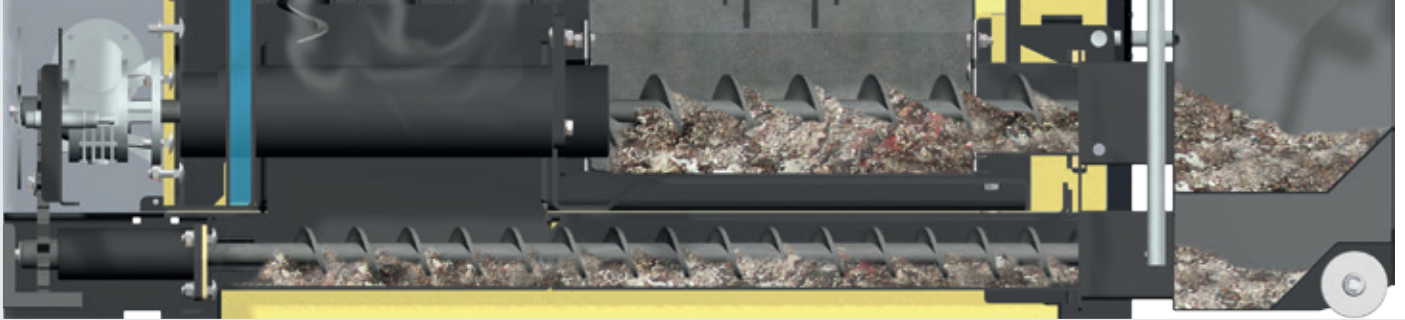

Ash is automatically emptied from the combustion chamber and the heat exchanger into the ash container using two separate ash screws, which are powered by a communal geared motor.

This ensures a clear separation and absolute tightness between the combustion chamber and the heat exchanger and eliminates the risk of air leaks.

**Feature: automatic ash removal**

- Advantages:
- little cleaning required
  - easy to empty ash container (available in three sizes: 36 l, 54 l, 72 l)
  - optional ash discharge into dustbin

The ash accumulated in the combustion chamber and the heat exchanger during combustion is automatically fed into a shared ash container.

The boiler controller informs you when the ash container needs emptied. It is easy to handle thanks to its transport wheels and holding bar. A cover flap also ensures that no ash can fall out of the container during transportation.

**Optional: Ash discharge system with bin**

For added convenience, ash can optionally be emptied into a standard 240 l dustbin. The ash is automatically conveyed into the dustbin where it can be easily emptied. This ensures long emptying intervals and maximum convenience.

# Intelligent upgrade

## Option: ESPF electrostatic precipitator

Froling's fine particulate air filter is the first electrostatic precipitator on the market especially designed for Froling boilers. Thanks to its compact design and easy assembly, it is even perfect for small boiler rooms. Thanks to its high separation rates of up to 85%, the fine particulate air filter guarantees safe compliance with future flue gas standards.

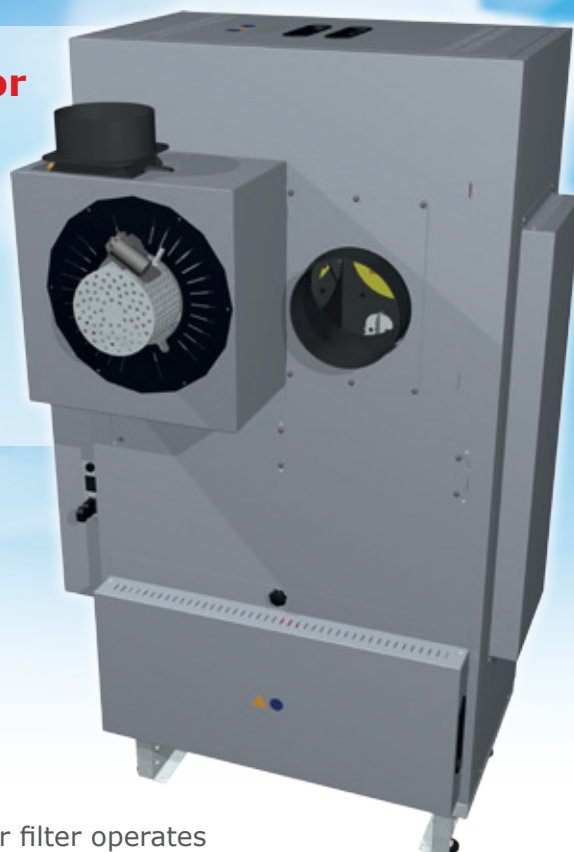

### How it works

Froling's fine particulate air filter operates on the electrostatic principle.

The flue gas from the boiler flows together with the fine dust particles (1) produced during combustion into the filter, where electrons (3) are released from the high voltage electrodes (2), which electrostatically charge the dust particles. The charged dust particles (4) then move towards the collecting electrode (5) where they are removed.

The accumulated dust particles (7) are rinsed away at regular intervals with flushing water (6).

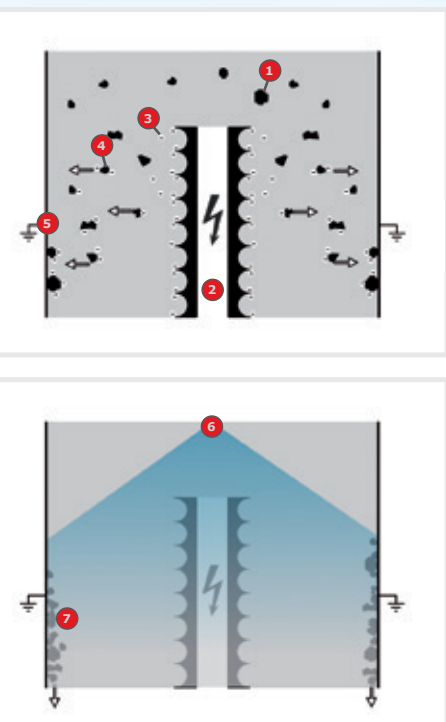

### Advantages

- Low energy consumption (approx. 30W in filter operation)
- Compact construction and easy to assemble on site
- Fully automatic filter cleaning using water
- Optimal fine dust removal (60 - 85% depending on fuel and dust composition)
- Durable and low-maintenance
- Integrated bypass flap for smooth boiler operation
- Available for Froling wood chip boilers T4 24 - 150 kW

## Unique: Condensing boiler technology for wood chip boilers



The Froling T4 (24 and 50 kW) is the only wood chip boiler in the world, which is also available with innovative condensing boiler technology (optional). The flue gas contains energy, which escapes unused up the chimney with conventional solutions, but an additional heat exchanger positioned on the back of the boiler makes use of it for the heating system. This increases the **boiler efficiency to over 105 percent (Hu)**, an unprecedented level for wood chip boilers. Froling won the innovation prize at the ExpoEnergy trade fair in Wels for condensing boiler technology in the biomass sector as early as 1996, making it a pioneer in the field. The heat exchanger is made of high-quality stainless steel. It is cleaned using a water flushing system. The module can also be retrofitted.

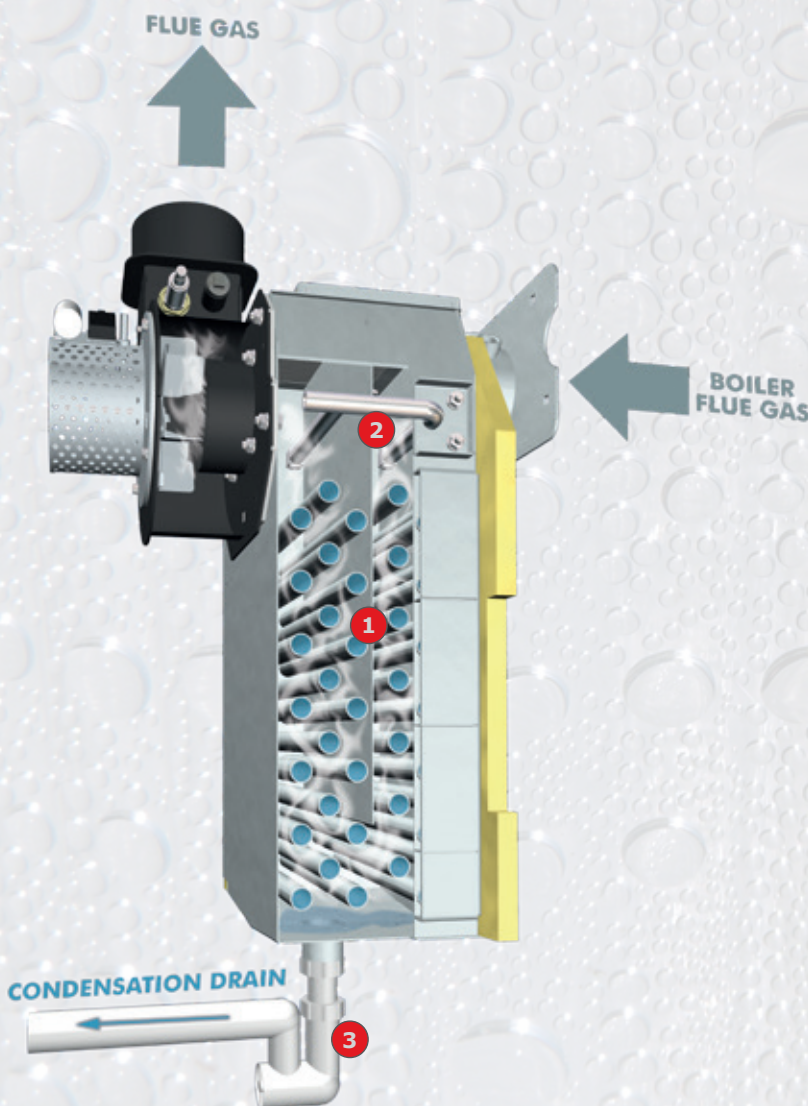

### Overview of condensing boiler heat exchanger:

- 1 Stainless steel heat exchanger
- 2 Automatic flushing equipment
- 3 Drain with siphon to remove condensation

### Requirements for optimal use of condensing boiler technology:

- The lowest possible return temperature (e.g. floor or wall heating)
- Moisture-resistant and soot fire-resistant flue gas system
- Duct connection for drainage of condensation and flushing water



# Fuel transport

- 1 Robust agitator head.
- 2 Maintenance-free agitator gearbox.
- 3 Powerful spring piles for even fuel transport (for wood chips up to P31S / G50)
- 4 Trough channel and feed screw with progressive screw blade.
- 5 Ball joint for continuously adjustable inclination.
- 6 Patented twin-chamber rotary valve for top burn back protection.
- 7 Sturdy stoker screw for reliable fuel feed with automatic turn control.
- 8 Energy-saving, powerful spur gears.
- 9 Temperature monitoring device in the fuel store (only required in Austria).
- 10 Easy access to the shear edge through an accessible opening.
- 11 Monitored gravity shaft cover.

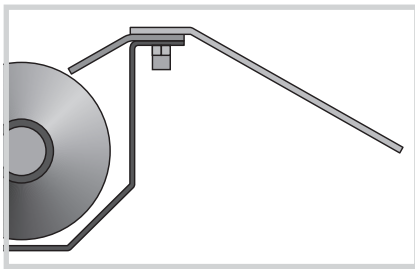

## No sloping sides required

None of Froling's discharge systems requires sloping sides. Without sloping sides, the raising plate fitted to the trough ensures simple operation.

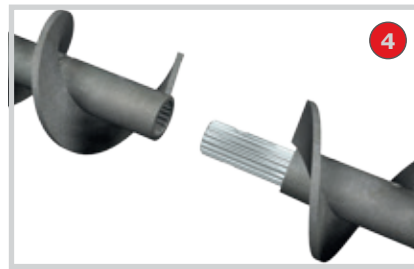

## Modular screw system

The plug-in screw system with standard extension pieces between 100 and 2,000 mm (graduations every 100 mm) allows easy assembly and flexible positioning of the system in the boiler room.



## Optional fibre shredder

If the material is particularly fibrous, the optional fibre shredder can shred long parts, thus ensuring reliable transportation of the material.

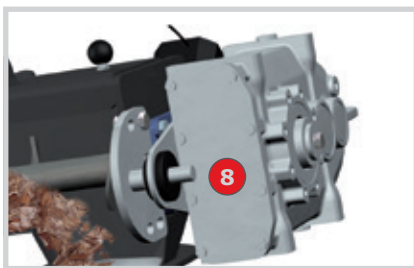
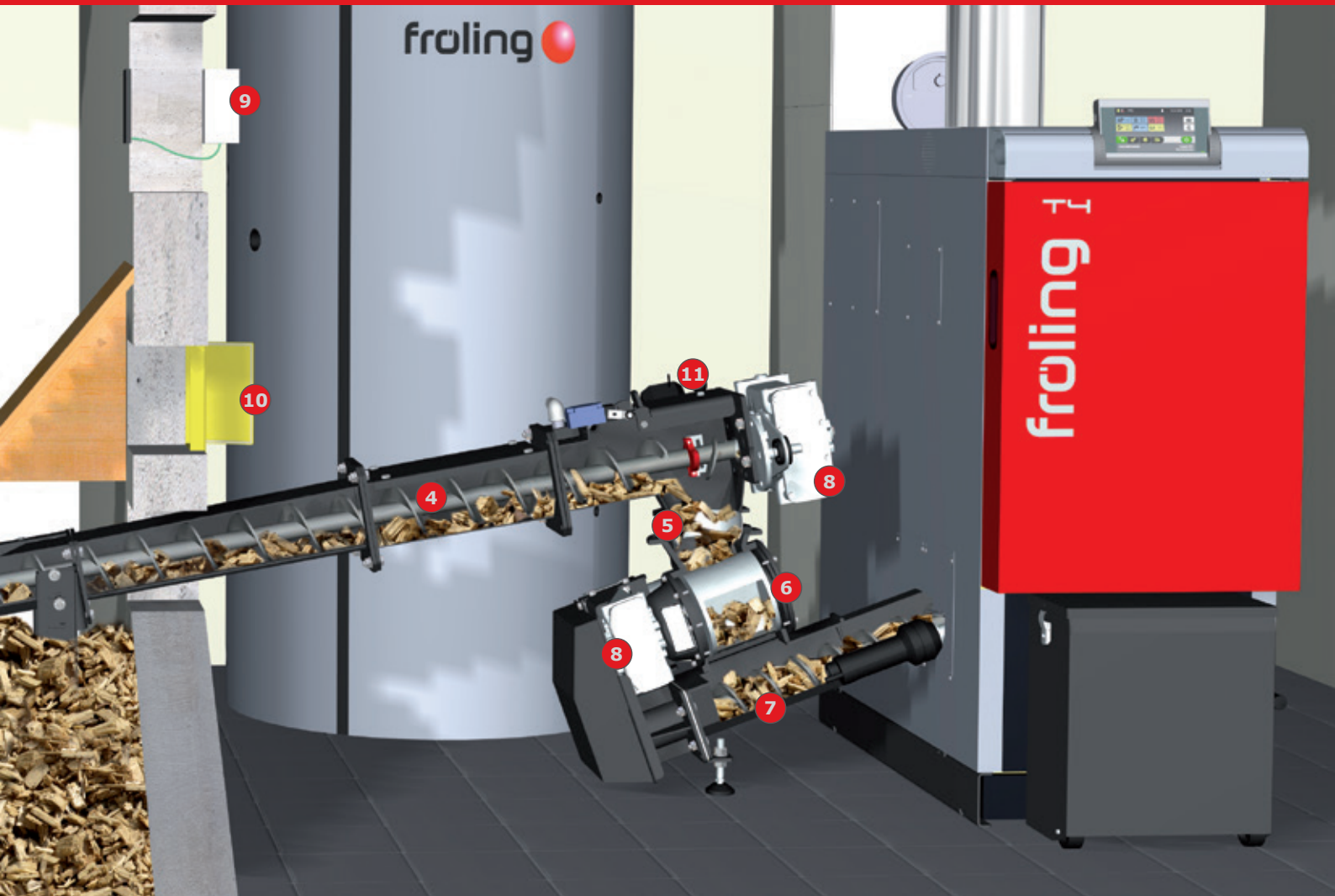

### Powerful spur gears

The powerful, energy-saving spur gears with a drive power of 0.25 kW ensure that even larger wood chip pieces can be shredded and transported. This design strikes the perfect balance between power and service life.



### Flexible ball joint

The ball joint is a flexible connecting piece between the discharge screw and the stoker unit. Offering continuous adjustment of the inclinations (up to 15°) and angles, the ball joint allows flexible planning.



### Patented rotary valve

The patented rotary valve with two large chambers offers maximum burn back protection and continuous material transport.

# Intelligent features

## Feature: **sturdy stoker unit**

- Advantages:
- flexible set-up
  - top burn-back protection
  - low energy consumption

The extremely compact stoker unit of the Froling T4 in combination with the patented rotary valve guarantees maximum burn back protection and reliable fuel feed to the combustion zone. The stoker unit is driven together with the rotary valve by an energy-saving geared motor (spur gears), thus guaranteeing maximum energy efficiency.

Froling offers the stoker screw in two sizes ( $\varnothing$  80 mm and  $\varnothing$  100 mm), the optimum solution for safe fuel transport from wood chips to P31S (previously G50). From the T4 40, the stoker screw has a diameter of 100 mm.

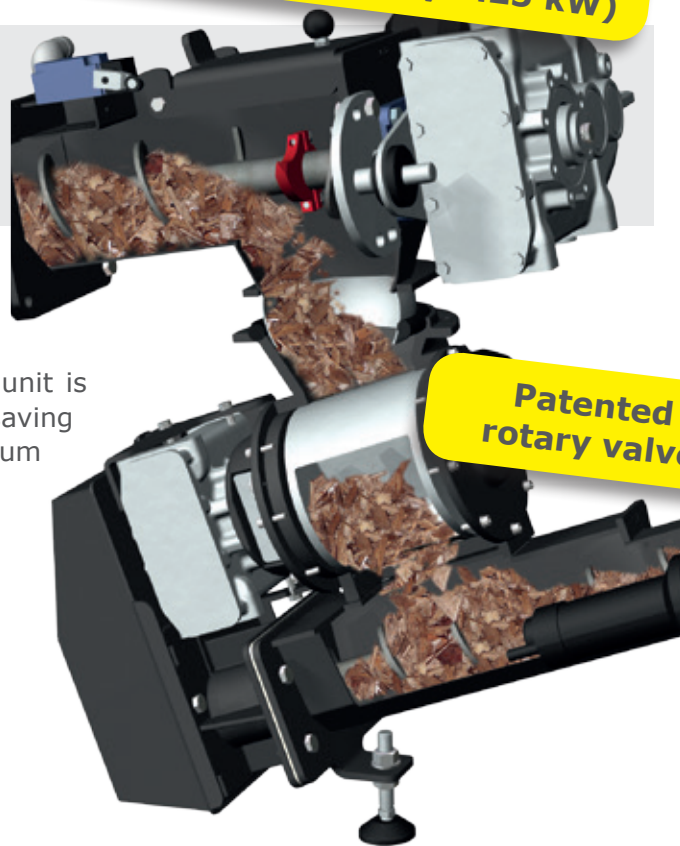

## Feature: **progressive metering screw with modular plug-in system**

- Advantages:
- flexible set-up
  - reliable material transport
  - low energy

The progressive feed screw guarantees reliable fuel transport. Thanks to the progressive screw raise, the material does not get compacted and can always be moved on easily. This ensures less force and energy consumption.

The modular design of the feed screw with standard extension pieces between 100 and 2,000 mm (graduations every 100 mm) allows easy assembly and flexible positioning of the system in the boiler room.

The Froling feed screw does not require sloping sides.

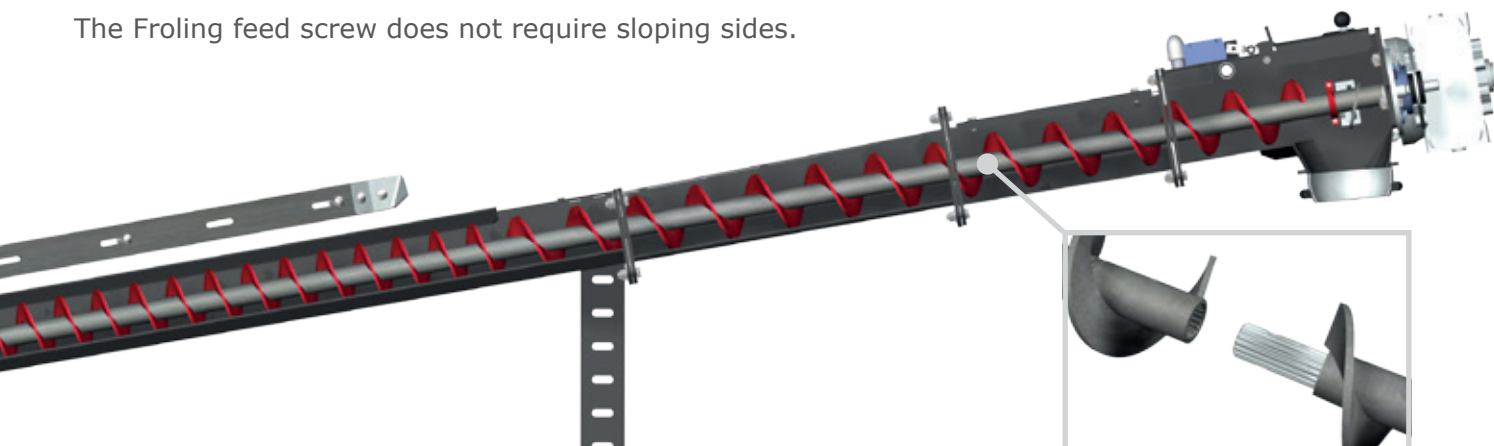



**Feature: patented twin-chamber rotary valve**

- Advantages:
- continuous flow of material
  - maximum burn-back protection
  - suitable for P31S (previously G50) wood chips

The patented twin-chamber rotary valve offers maximum operating safety. The rotary valve forms a reliable separation between the discharge system and the feed unit, providing optimal burn back protection. The advanced system design with two spacious chambers ensures that the fuel is transported continuously to the combustion zone. This optimal fuel metering ensures the best possible combustion values.

The two large chambers are especially suitable for transporting wood chips up to P31S (previously G50). High resistance is recognised automatically. The rotary valve and screw move backwards (several times depending on the parameters set) until transport can be re-started.

The rotary valve is extremely quiet and uses only minimal power.

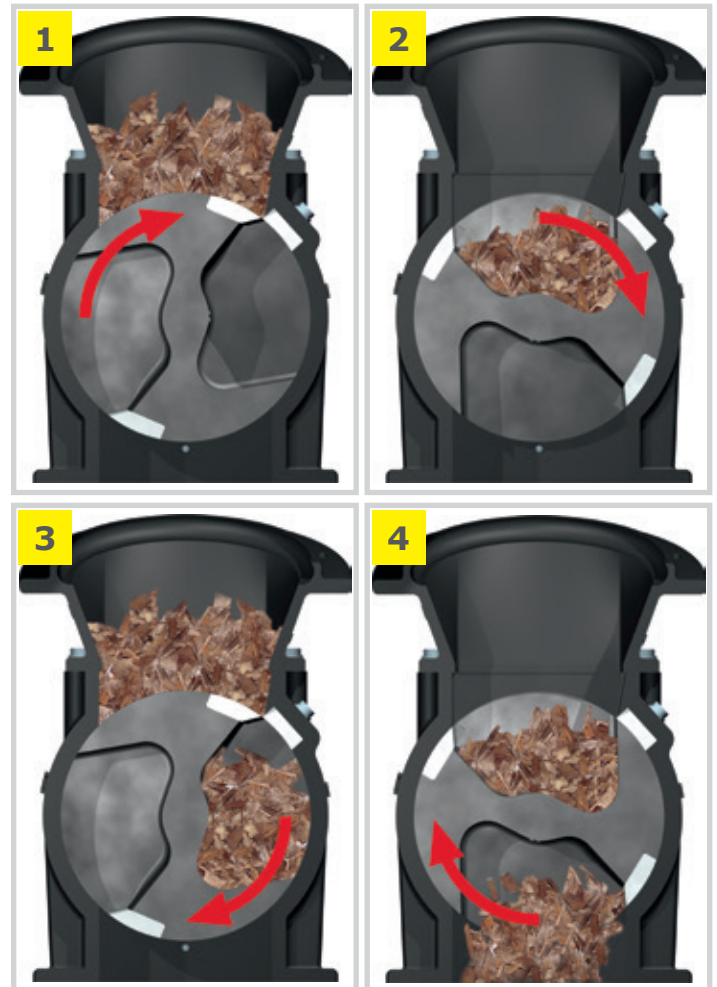
**Replaceable blades**

The high-quality cutting edges of the blades can also easily cut through coarser pieces of wood chip. The blades both in the rotor and the housing can be simply removed and sharpened if necessary.

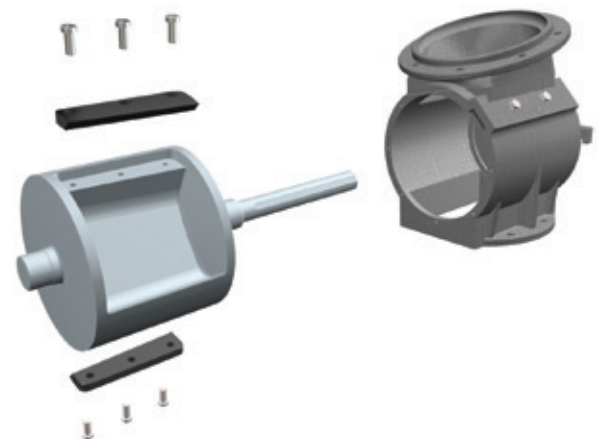

# Froling discharge systems

## Rotary agitator discharge systems with combined drive

The simple and effective design of Froling's rotary agitator discharge systems ensures smooth operation. Any problematic materials (e.g. foreign bodies) are automatically detected and removed by a reverse turn of the screws (turn control). The feed screw with progressive screw raise ensures low energy consumption.



### Spring blade agitator (FBR)

Maintenance-free system with a max. working diameter of 5.5 metres. Designed for fuels that trickle easily (e.g. wood chips P16S/P31S to M35, previously G30/G50 to W35).

### TGR/SGR articulated arm rotary agitator

Maintenance-free system with patented design and a max. working diameter of 6.0 metres. Designed for fuels requiring greater discharge power due to their limited ability to trickle.

## Features for effective operation

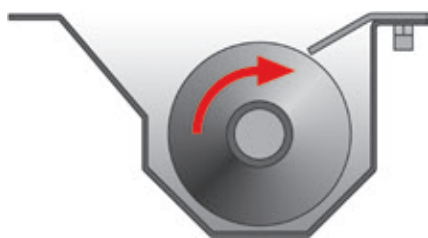

### Screw channel

The special trapezoidal shape of the trough ensures that fuel transport runs smoothly. The system is easy to operate so it saves energy even when feeding in the maximum amount of pellets.



### Shear edge

The robust shear plate with cutting edge breaks up larger pieces of fuel guaranteeing continuous fuel feed.



### Rotary agitator arms with tearing hooks

The powerful rotary agitator arms move towards the agitator head during filling and then swing back out when fuel is removed.

Together with the sturdy tearing hooks that loosen the fuel, they ensure that the fuel store is emptied.

## Rotary agitator discharge systems with separate drive

Froeling's rotary agitator discharge systems with separate drive offer even greater flexibility. In the FBR-G and TGR-G the rotary agitator is powered independently of the discharge screw. This allows flexible installation and variable adjustment of the feed output. The discharge screws can be positioned on both the left and right of the rotary agitator.

There is also the option of using extra long discharge screws. This system means that the fuel can even be optimally fed from the back of the fuel store.

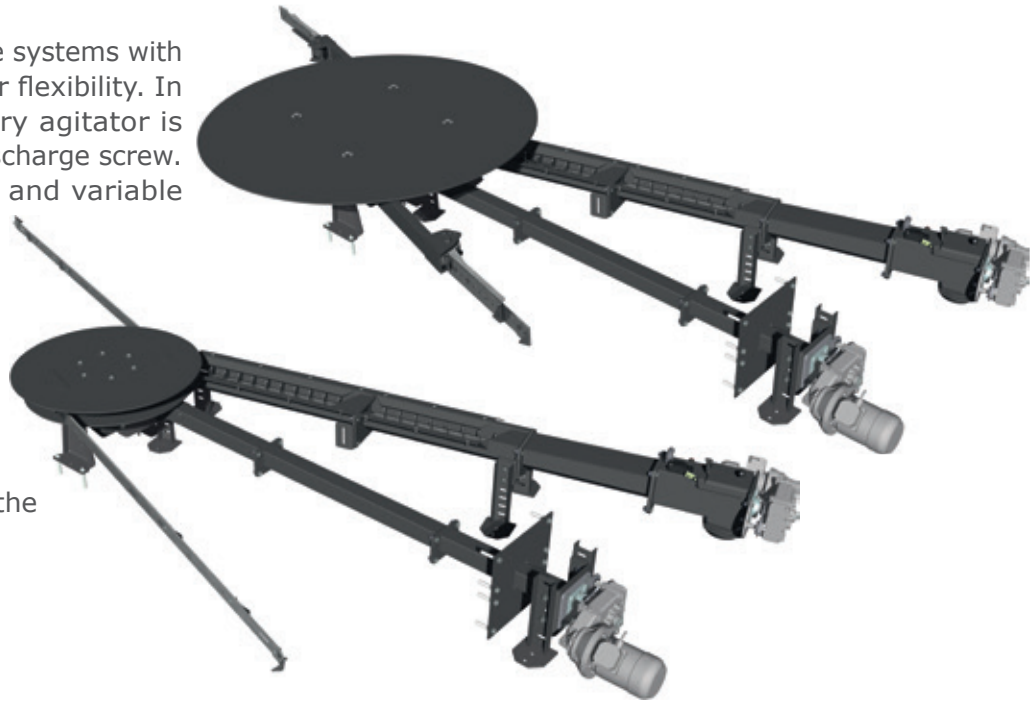

### Sample installation options

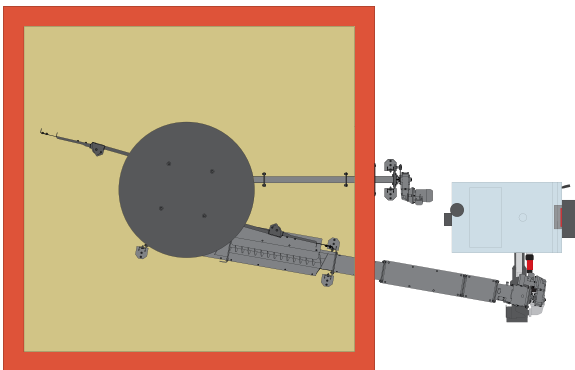

One discharge screw on the left

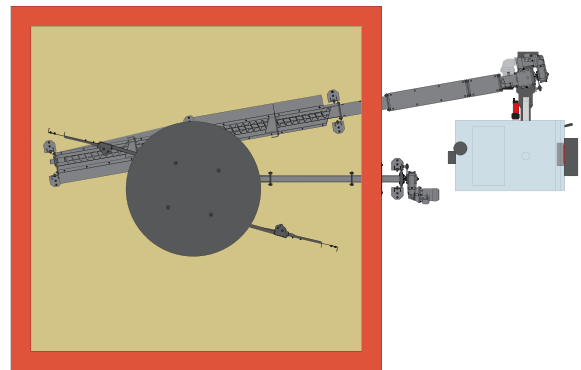

One extra-long discharge screw

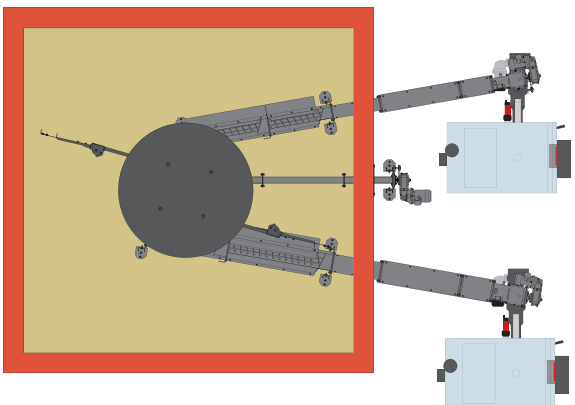

Dual boiler system with two discharge screws

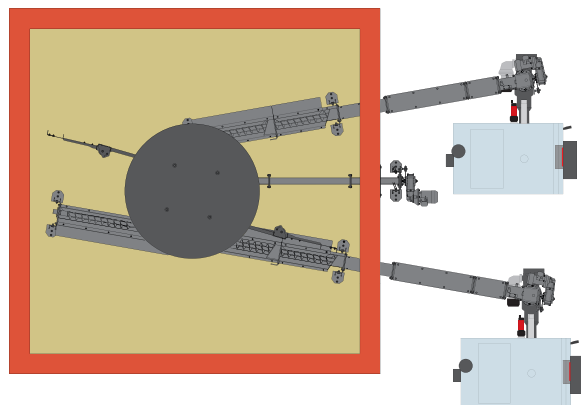

Two discharge screws, one standard, one extra-long



# Bunker filling systems

## Vertical feed screw



also available with horizontal distributor screw

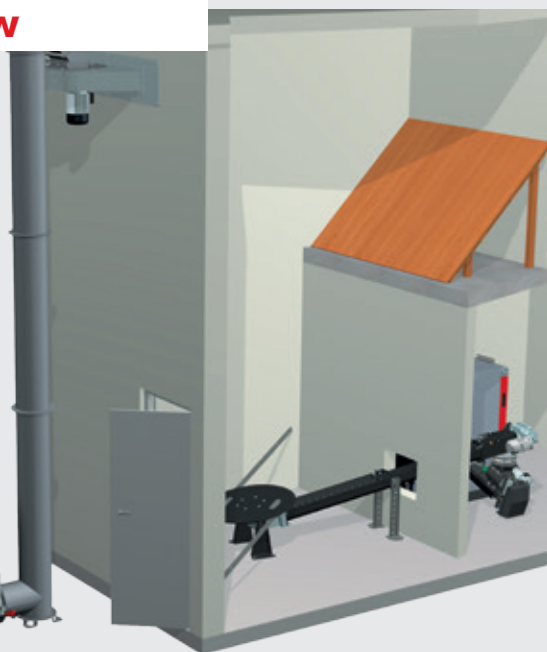
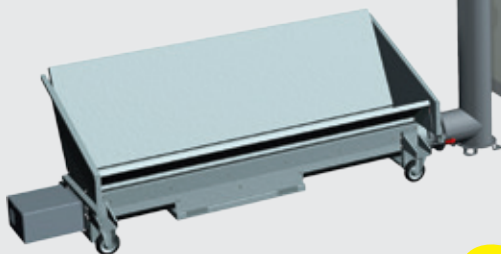

Froling's vertical feed screw sets new standards for feed output (up to 45 m<sup>3</sup>/h), operating safety and effective distribution. The wood chips are pushed from the tipping gutter into the vertical feed system with a screw, which transports the fuel to the desired height for the distribution device. In this way, the vertical feed screw enables dust-free filling of the store, guaranteeing even distribution of the fuel.

For more information see our "Store filling systems" brochure

## Bunker filling screw

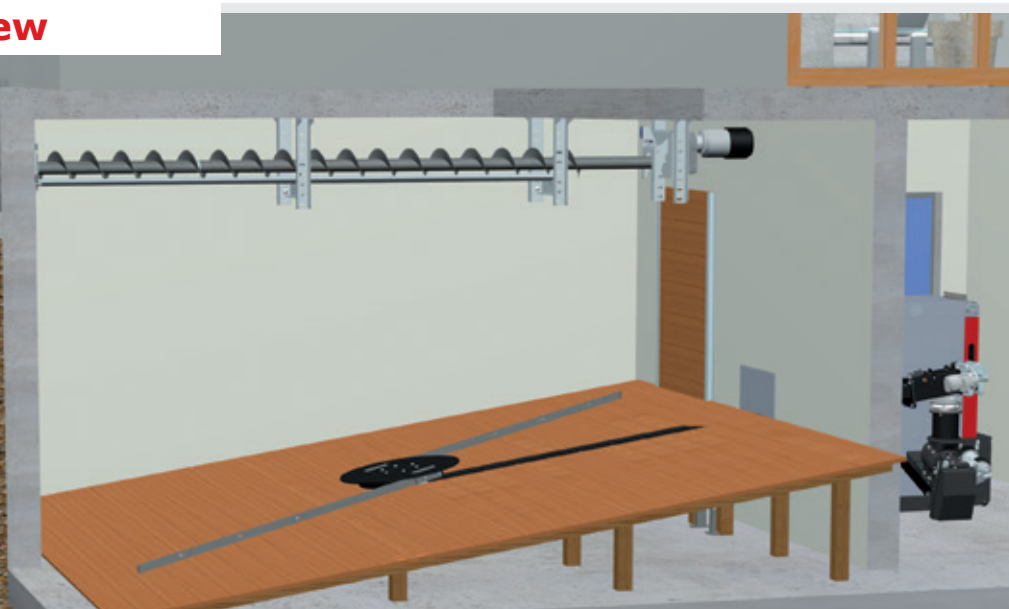

The fuel is transported using the bunker filling screw into the store space via the tipping chute which is located outside the store. The bunker filling screw stops automatically when the bunker is full. The sloping sides shown in the fuel store are not required for the discharge to work properly.

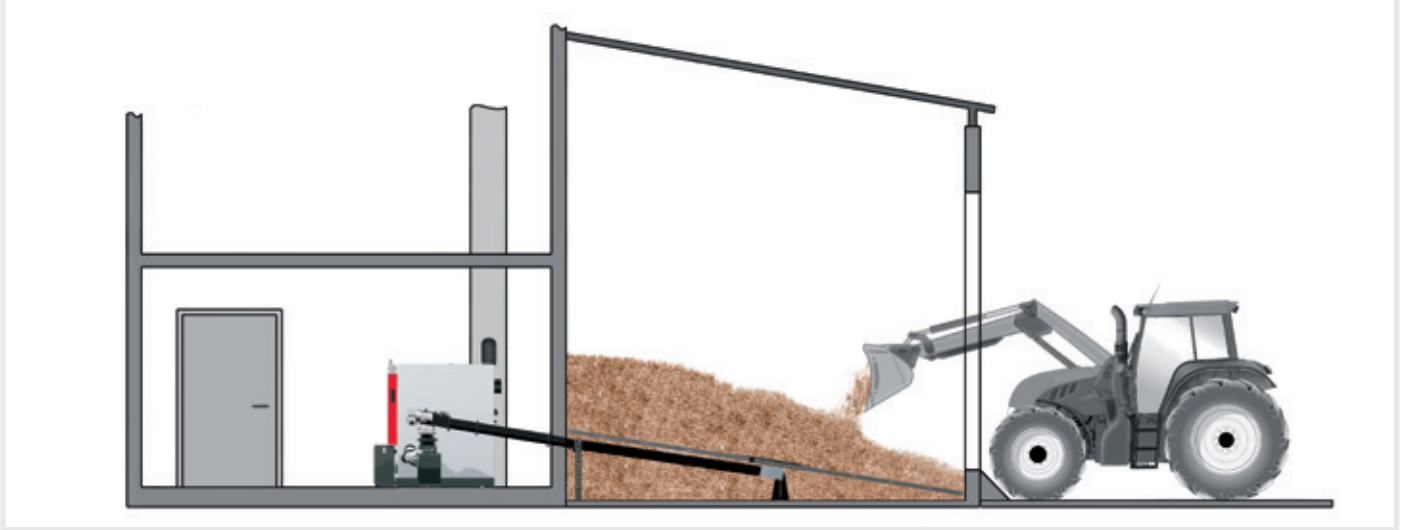
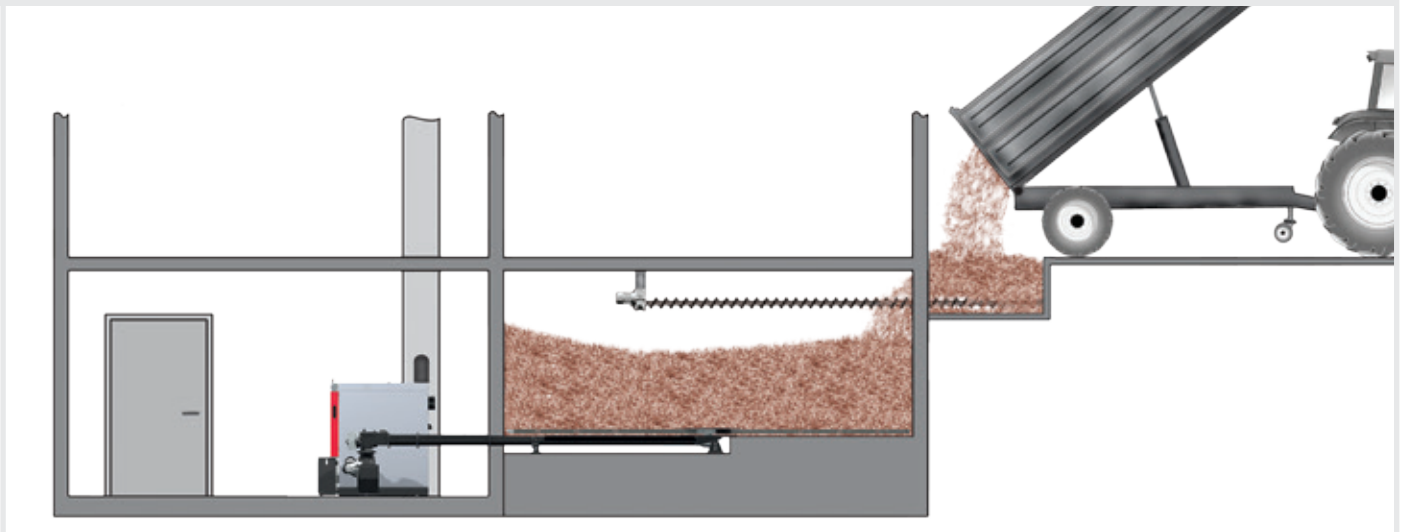
**Positioning at ground level****Positioning with bunker filling screw****Positioning with vertical screw**

# Flexible complete solutions

## Froling energy box

Heating containers make it possible to move the boiler room and store, ensuring space savings and enabling installation of biomass heating, particularly during renovation of an existing building. The Froling energy box has been planned carefully down to the last detail: the boiler, feed system, fuel store (and the storage tank and chimney system depending on the design) are perfectly matched.

The Froling energy box is delivered by lorry and can be put into operation quickly. All installation steps are clearly defined from the start based on the system design.

- Concreting of foundations under the longitudinal walls (carried out by the customer)
- Delivery of the Energy box
- Assembly of the heating components
- Connection to heating and water by the Froling partner installer
- Commissioning





**Feature: intelligent system design**

- Advantages:
- relocation of the boiler room and store
  - all-in-one system
  - perfectly matched components

The Froling Energy Box is an all-in-one complete solution. All components are perfectly matched to each other.

- Froling T4 wood chip system
- spring blade agitator SBA
- high-quality stainless steel chimney
- store door 80x200 cm
- prefabricated reinforced concrete container with all necessary recesses and openings
- wide range of special accessories (bunker filling systems, layered tanks, etc.)

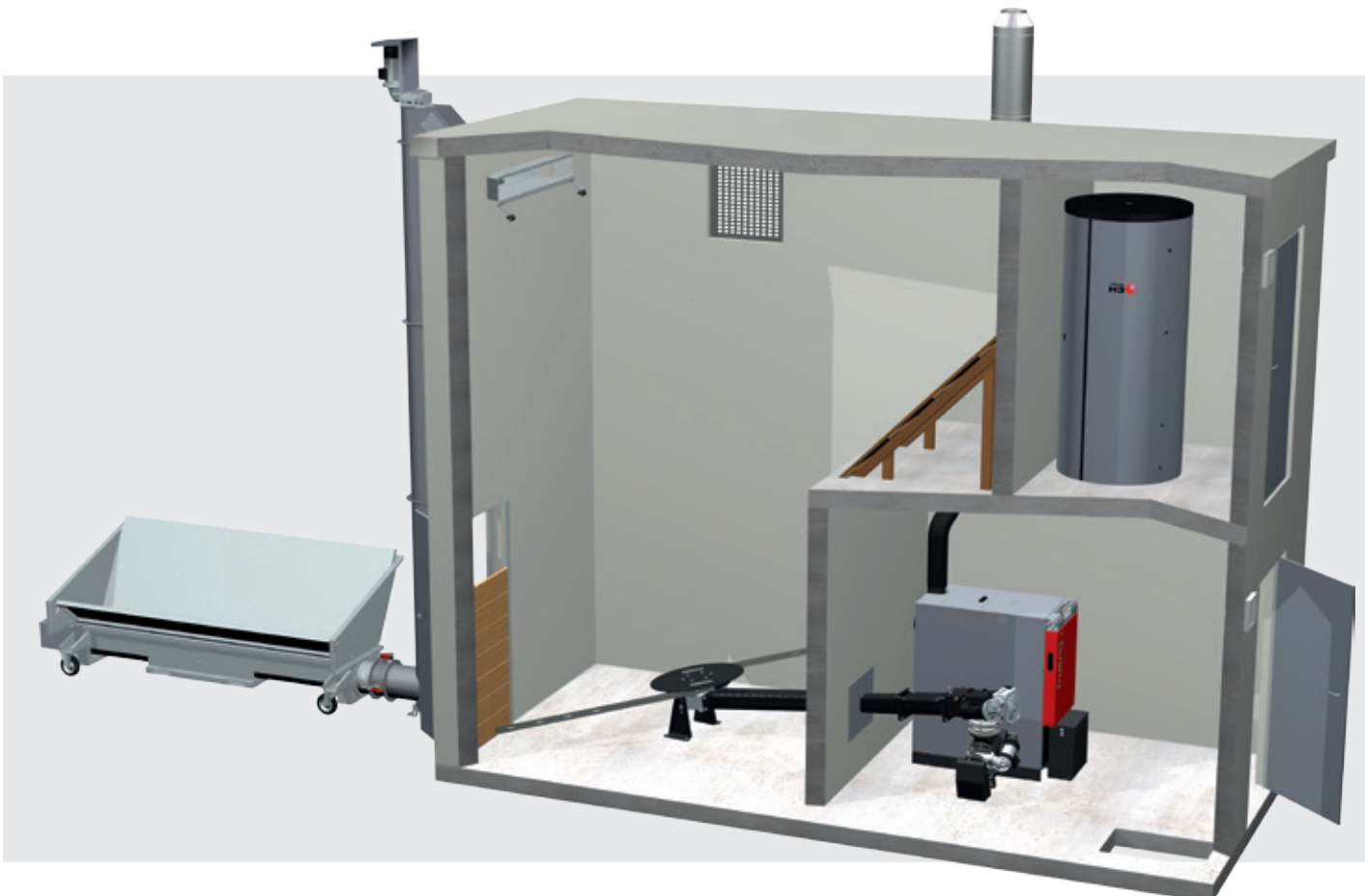
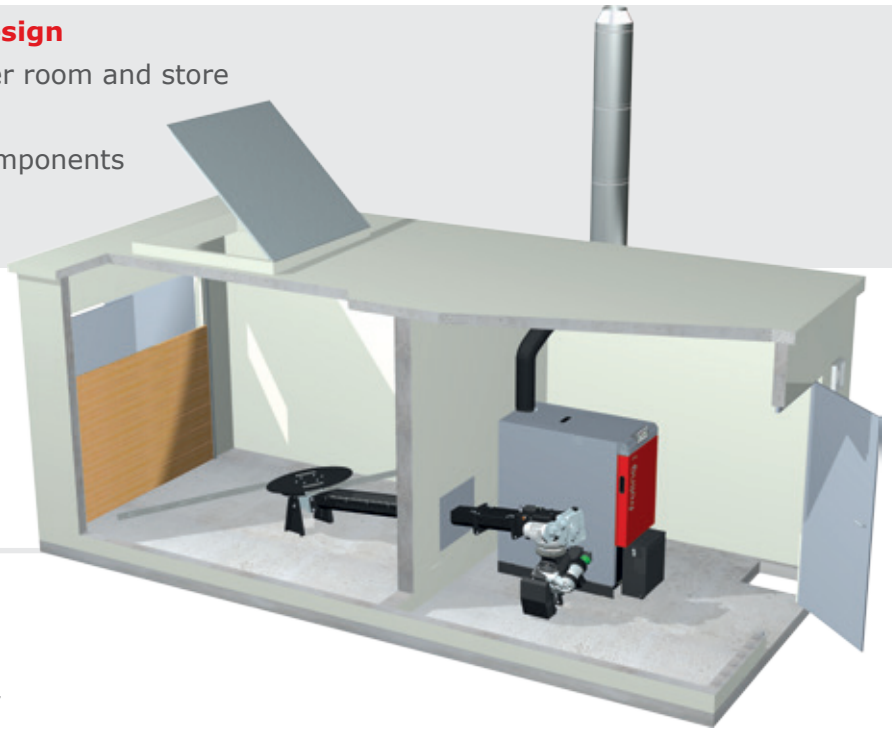

# Systematic convenience

## Lambdatronic H 3200 control

With the new Lambdatronic H 3200 boiler controller, Froling is taking a step into the future. The control unit is optimised to suit any requirement. An individually adjustable viewing angle ensures that all operating statuses are clearly displayed. Exact combustion control thanks to lambda control **with broadband probe** as standard.

The menu structure is ideally organised to ensure easy operation. All essential functions can be selected by simply pressing a button.



## Lambdatronic H 3200 control

Advantages:

- Exact combustion control with broadband probe lambda control
- Large, clear control unit

## NEW! 7" Touch-Display

Advantages:

- Individual installation of your own heating system
- Even more comfortable operation of the boiler thanks to a larger touch screen

## Accessories for even greater ease of use



### FRA room temperature sensor

By using the Froling FRA room temperature sensor (measuring only 8x8 cm), the main modes of the corresponding heating circuit can be easily selected and adjusted. The FRA room temperature sensor can be connected with or without affecting the room area. The adjusting wheel allows you to change the room temperature by up to  $\pm 3^{\circ}\text{C}$ .

## RBG 3200 room console

The RBG 3200 room console makes the system even easier to use. The heating system is conveniently controlled from your living room. All important system data is clearly displayed on the 19x8 cm console and settings can be changed at the push of a button.



### RBG 3200 Touch room console

The RBG 3200 Touch has an impressive touchpad interface. The menu structure means it is intuitive and easy to use. The 17x10 cm console with colour screen shows the most important functions at a glance and automatically adjusts the background lighting to the conditions. The room consoles are connected to the boiler controller using a bus cable.



Online controller  
**froeling-connect.com**



Froling's new online control, [froeling-connect.com](http://froeling-connect.com), allows you to check and control your Froling boiler with boiler touchscreen anytime, anywhere. You can read or modify the main status information and settings easily and conveniently online (from your PC, smartphone, tablet PC, etc.). You can also specify which status messages you would like to receive by text message or e-mail. The new [froeling-connect.com](http://froeling-connect.com) service allows the owner of the heating system to enable additional users - for example the installer, a neighbour, etc. - to access the boiler and monitor the heating system, during holidays for instance.



Individual access rights

Customer  
 Installer  
 Customer service



Platform-independent  
 Operate the heating system online



System requirements:

- Froling boiler (core module software version V54.04, B05.09) with boiler touchscreen (software version V60.01, B01.20)
- broadband internet connection
- Froling boiler internet connection via network
- web-enabled terminal device (smartphone/tablet PC/laptop/PC) with web browser



# Perfect connections

**Feature:** systems engineering for optimum energy consumption

- Advantages:
- complete solutions for all requirements
  - the components work perfectly together
  - integrated solar power

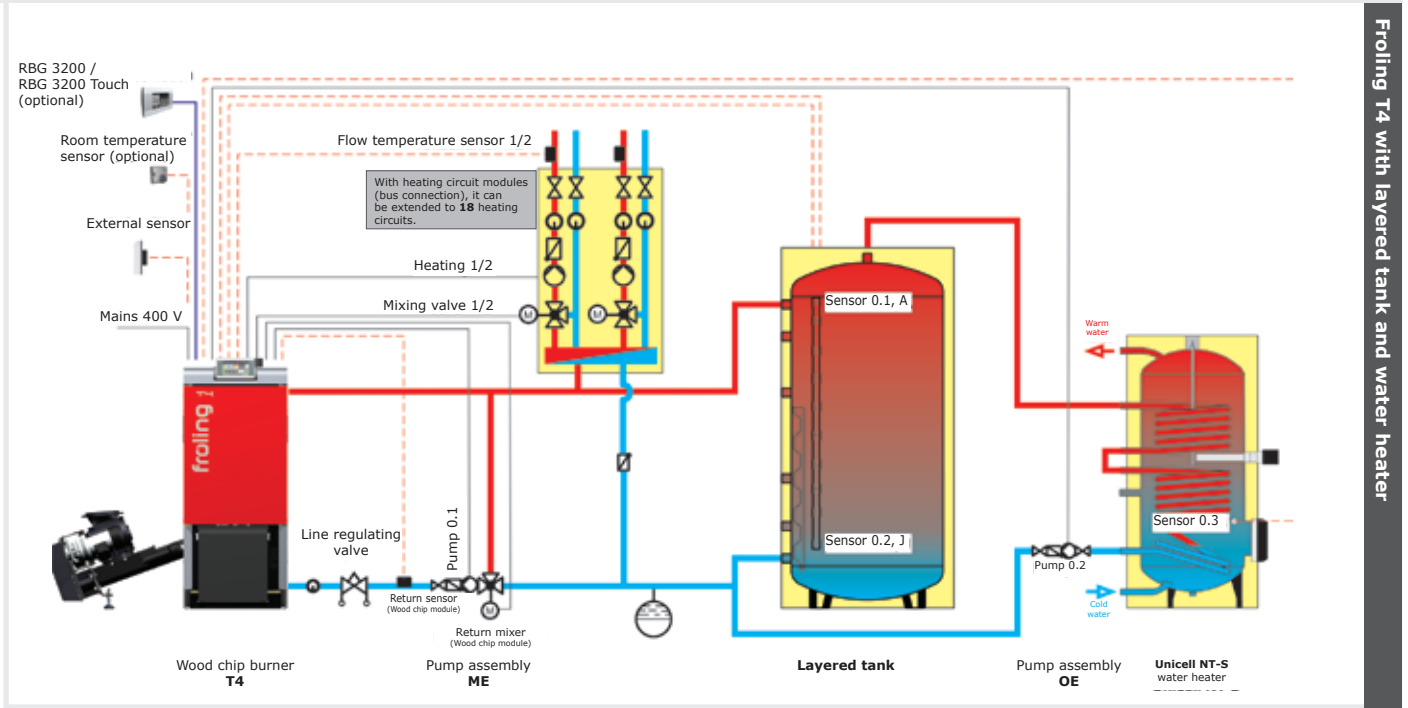

## Multi-sensor storage tank management

Minimal start-stop cycles

High system efficiency

Optimised for cascade systems

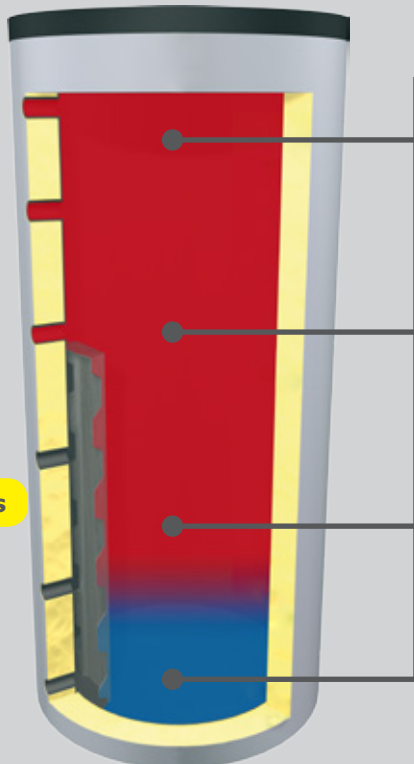

### Precise storage tank level with four sensors

In addition to conventional storage tank management with two sensors, Froling also offers the option of multi-sensor storage tank management. For this function four sensors are distributed along the entire height of the storage tank. The controller then uses these to determine the storage tank fill level. The controller can thus quickly identify load changes and adjust the boiler output early on. Fewer start-stop cycles result in a long boiler life and maximise the system efficiency.

The **Froling bus system** makes it possible to install extension modules at any location. The local controls can be installed wherever they are needed: at the boiler, at the heat distributor, at the tank, in the living room or in the house next door. Additionally, electric cables are kept to a minimum.

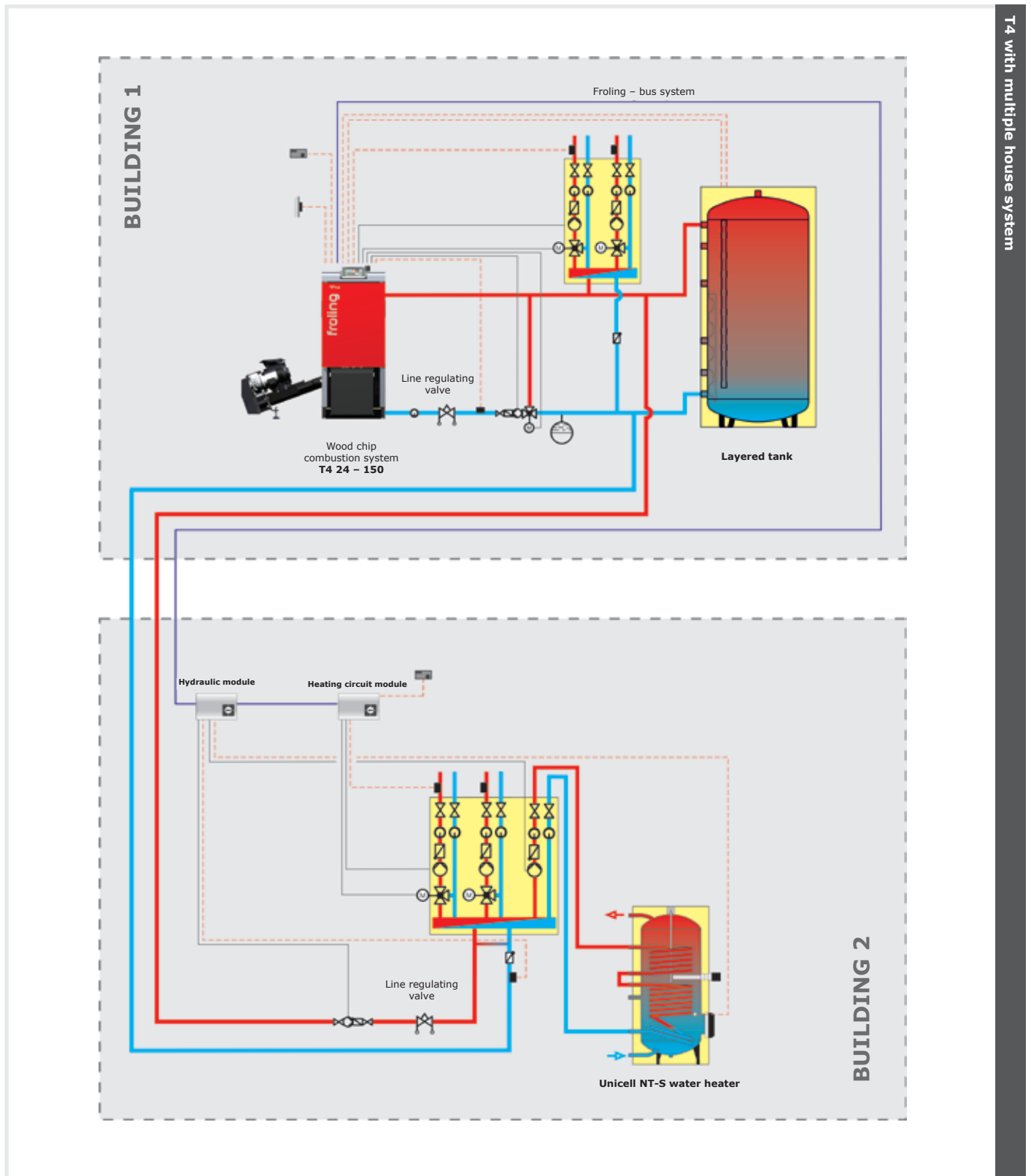

T4 with multiple house system

# Technical specifications

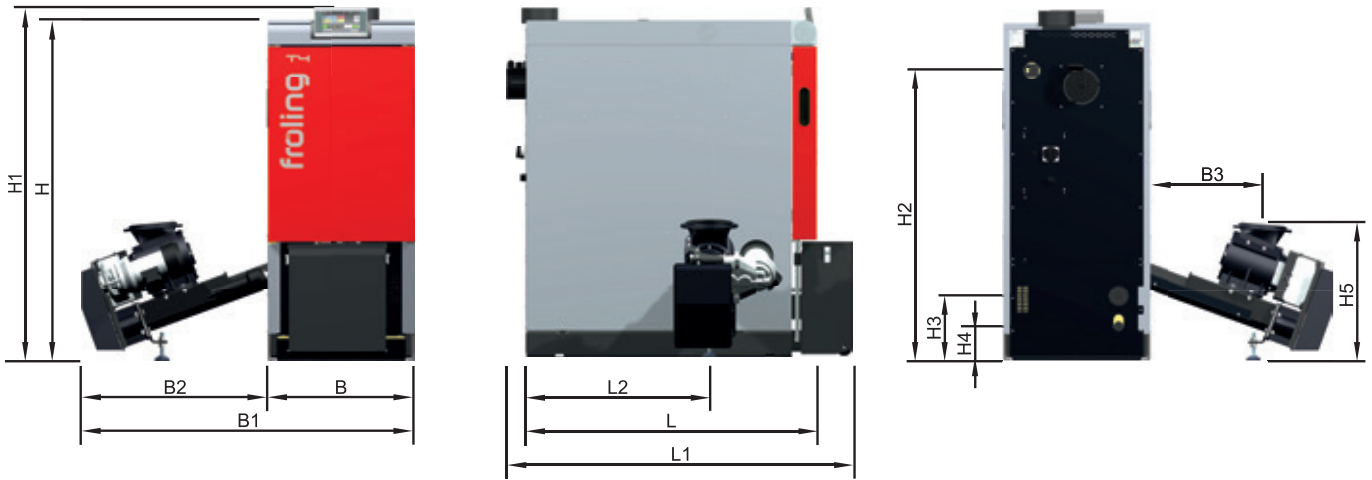

T4 dimensions			24 / 30	40 / 50	60 / 75	90 / 100 / 110	130 / 150
<b>H</b>	Height of boiler	[mm]	1390	1620	1620	1720	1720
<b>H1</b>	Height of flue gas pipe connection	[mm]	1440	1670	1670	1770	1770
<b>H2</b>	Height of flow connection	(mm)	1195	1425	1425	1530	1540
<b>H3</b>	Height of return connection	[mm]	270	270	270	170	200
<b>H4</b>	Height of drain	[mm]	140	140	140	140	140
<b>H5</b>	Height of stoker connection	[mm]	580	650	650	650	650
<b>W</b>	Width of boiler (=positioning width)	[mm]	600	770	770	880	880
<b>W1</b>	Total width with stoker unit	[mm]	1360	1530	1530	1640	1640
<b>W2</b>	Width of stoker unit	[mm]	760	760	760	760	760
<b>W3</b>	Distance from side of the boiler to stoker connection	[mm]	470	470	470	470	470
<b>L</b>	Length of boiler (=length for positioning)	[mm]	1200	1200	1570	1570	1905
<b>L1</b>	Total length incl. induced draught fan and ash container	[mm]	1430	1430	1920	1920	2300
<b>L2</b>	Distance from back of boiler to stoker connection	[mm]	755	755	1045	1045	1305

## Recommended distances in the installation room

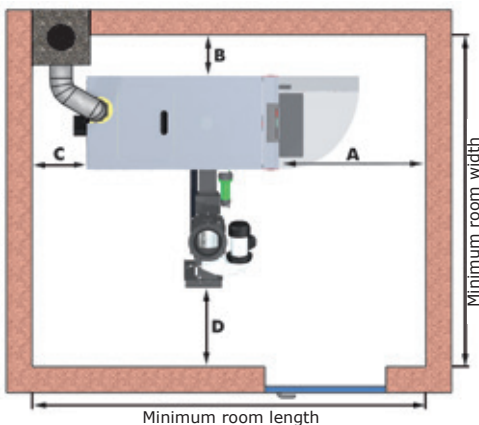

Distance [mm]	24/30	40/50	60/75	90 - 110	130/150
<b>A</b> Distance from insulating door to wall	600	800	800	900	900
<b>B</b> Distance between boiler side and wall	200	200	200	200	200
<b>C</b> Distance between rear of boiler and wall	500	500	500	500	500
<b>D</b> Distance between stoker and wall	300	300	300	300	300
Recommended room length	2300	2500	2870	2970	3305
Recommended room width	1860	2030	2030	2140	2140
Recommended room height	1700	1900	1900	2150	2150



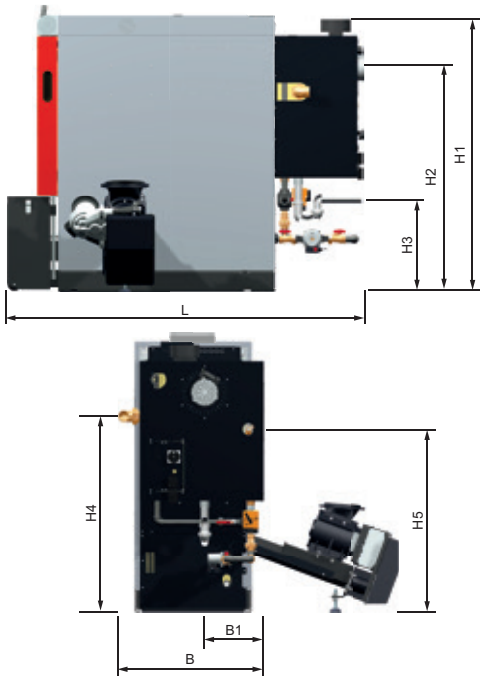

Dimensions - T4 with condensing boiler technology		T4 24
H1	Height, flue gas pipe connection [mm]	1375
H2	Height, ID fan connection [mm]	1130
H3	Height of condensation drain connection (DN40) [mm]	340 - 540
H4	Height of return connection [mm]	1010
H5	Height of flushing device connection (1/2") [mm]	940
W	Width of boiler with return connection [mm]	750
W1	Distance between condensation drain and side of boiler [mm]	300
L	Length of boiler with condensing boiler heat exchanger [mm]	1805
Boiler efficiency <sup>1)</sup> (wood chips nominal load / partial load) [%]		105,0 / 100,5
Boiler efficiency <sup>1)</sup> (pellets nominal load / partial load) [%]		105,7 / 99,6
Flue gas temperature <sup>2)</sup> [°C]		35 - 45
Condensation / nominal load hour (pellets) <sup>3)</sup> [litres]		2,0 - 2,5
Condensation / nominal load hour (wood chips) <sup>3)</sup> [litres]		2,0 - 3,0
Flushing device connection [inches]		1/2
Condensation drain connection		DN40
Energy (ErP) label T4 24 - 50 kW <sup>4)</sup>		A++

- 1) Boiler efficiency in relation to heating value Hu  
 2) Flue gas temperatures indicated are dependent on heater return feed temperature  
 3) Amount of condensation indicated is dependent on heater return temperature and moisture content of the fuel  
 4) Composite label (boiler + controls + condensing heat exchanger)

ESPF 50/100

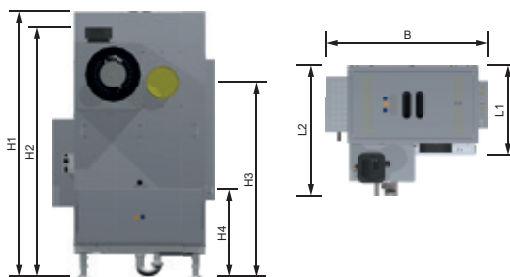

ESPF 250

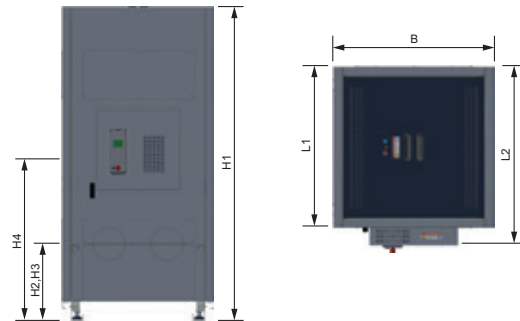

Electrostatic precipitator dimensions	ESPF 50 <sup>1)</sup> (T4 24-50)	ESPF 100 <sup>1)</sup> (T4 60-110)	ESPF 250 (T4 130-150)	
H1	Height of filter [mm]	1480 - 1750	1480 - 1885	1890
H2	Height of chimney connection [mm]	1395 - 1665	1435 - 1840	470
H3	Height of flue gas inlet [mm]	1090 - 1360	1090 - 1495	470
H4	Height of fresh water connection [mm]	490 - 760	510 - 915	950
W	Width of filter [mm]	900	900	900
L1	Length of filter [mm]	500	715	900
L2	Length of filter with fittings [mm]	725	960	1045
Electrical connection		230 V / 50 Hz / fused 13 A		
Power consumption [W]		30 - 40	70	150
Fresh water connection [inches]		1/2	1/2	1/2
Minimum pressure fresh water connection [bar]		3	3	2
Drain connection		DN40	DN40	DN40
Efficiency <sup>2)</sup> (separation rate) [%]		60 - 85		

- 1) The height of electrostatic precipitators ESPF 50 and ESPF 100 can be adjusted to the respective boiler type. The heights specified represent the adjustment range.  
 2) The actual separation rate depends on the fuel used and the dust composition in the flue gas.

# Technical specifications

T4 technical specifications		24	30	40	50	60	75
Rated heat output	[kW]	24	30	40	50	60	75
Output range	[kW]	7,2-24	9-30	12-40	15-50	18-60	22,5-75
Energy (ErP) label*		A <sup>+</sup>	A <sup>+</sup>	A <sup>+</sup>	A <sup>+</sup>	A <sup>+</sup>	
Boiler efficiency (wood chips nominal load / partial load)	[%]	92,3 / 91,6	91,0 / 91,6	92,1 / 92,4	93,1 / 93,2	93,1 / 93,3	93,0 / 93,6
Boiler efficiency (Pellets nominal load / partial load)	[%]	92,2 / 91,0	92,0 / 91,4	93,1 / 92,3	94,2 / 93,2	94,1 / 93,5	93,9 / 93,9
Power connection		400V / 50Hz / fused C16A					
Electrical power consumption (Pellets / wood chips)	[W]	74 / 115	84 / 142	86 / 150	88 / 158	102 / 176	122 / 204
Boiler weight (incl. stoker unit, excl. water)	[kg]	620	640	840	860	1060	1080
Boiler water capacity	[L]	105	105	160	160	220	220
Water pressure drop ( $\Delta T = 10/20$ K)	[mbar]	3,9 / 1,2	4,8 / 1,4	5,2 / 1,8	5,5 / 2,2	7,8 / 2,6	11,4 / 3,2
Maximum adjustable boiler temp.	[°C]	90					
Maximum operating pressure	[bar]	3					
Flue gas pipe diameter	[mm]	150	150	150	150	180	180

\* Composite label (boiler + controls)

T4 technical specifications		90	100	110	130	150
Rated heat output	[kW]	90	100	110	130	150
Output range	[kW]	27-90	30-100	33-110	39-130	45-150
Boiler efficiency (wood chips nominal load / partial load)	[%]	92,9 / 93,8	92,9 / 93,9	92,9 / 93,9	93,3 / 94,6	93,8 / 94,6
Boiler efficiency (Pellets nominal load / partial load)	[%]	93,6 / 94,3	93,5 / 94,6	93,5 / 94,6	93,7 / 94,5	93,8 / 94,5
Power connection		400V / 50Hz / fused C16A				
Electrical power consumption (Pellets / wood chips)	[W]	142 / 232	156 / 250	156 / 250	210 / 240	264 / 262
Boiler weight (incl. stoker unit, excl. water)	[kg]	1350	1360	1370	1730	1750
Boiler water capacity	[L]	260	260	260	340	340
Water pressure drop ( $\Delta T = 10/20$ K)	[mbar]	14,9 / 3,8	17,2 / 4,2	18,7 / 5,2	23,3 / 6,9	30,6 / 8,3
Maximum adjustable Boiler temp.	[°C]	90				
Maximum operating pressure	[bar]	3				
Flue gas pipe diameter	[mm]	200	200	200	200	200

Your Froling partner:



**Heizkessel- und Behälterbau GesmbH  
A-4710 Grieskirchen, Industriestr. 12**

AUT: Tel +43 (0) 7248 606 • Fax +43 (0) 7248 606-600  
GER: Tel +49 (0) 89 927 926-0 • Fax +49 (0) 89 927 926-219  
Email: [info@froeling.com](mailto:info@froeling.com) • Internet: [www.froeling.com](http://www.froeling.com)

P0530817 - All illustrations intended as a guide only. We reserve the right to make technical changes without prior notice.  
Errors and omissions excepted. Sources for external image material: [www.propellets.at](http://www.propellets.at), [www.aboutpixel.de](http://www.aboutpixel.de)